

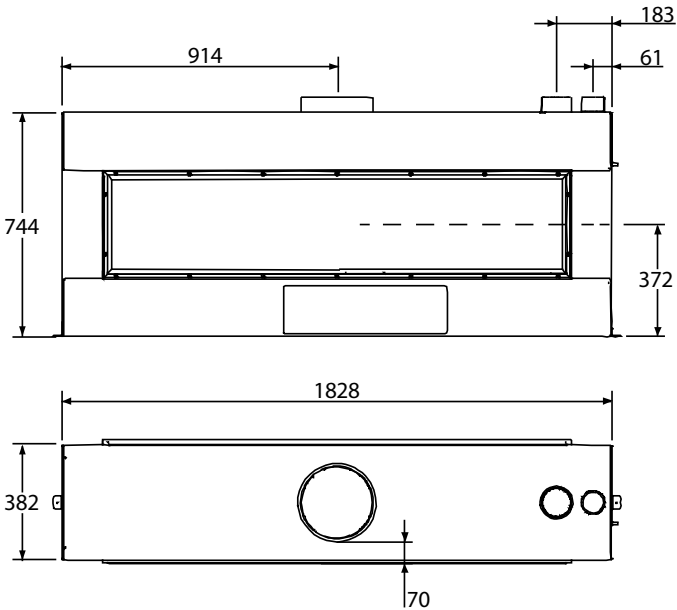

For further information or specifications, visit the technical section of our website www.escea.com to view the latest product Installation Manual.

Appliance Information

Product Dimensions



Gas Specifications

Heat Output	10kW*
Gas Input / Consumption	40MJ/hr*
Gas Connection	Lower right side of appliance, 1/2" BSP
Gas Type	Natural Gas / LPG (NZ) / Propane (Aus)
Operating Pressure	0.84kPa NG / 2.2kPa LPG or Propane
Inlet Gas Pressure	1.2kPa to 5.0kPa NG 2.5kPa to 5.0kPa LPG or Propane
Power Requirement	3 pin earthed 230V power outlet to be within 1.0m of right side of the appliance

* Internal results pending confirmation from test laboratory

Cavity Information

Minimum Cavity Dimensions (mm):

The appliance must be installed prior to and behind the finished wall surface. Take into account any plaster board, tiles or any other finishing surface that may be intended for the finished wall surface.

Wall finishing materials must not encroach upon the minimum cavity clearances shown.

The wall board that lines the outside of the opening can be normal plaster board and does not need to be non-combustible.

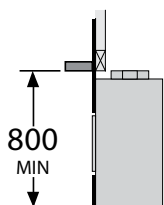
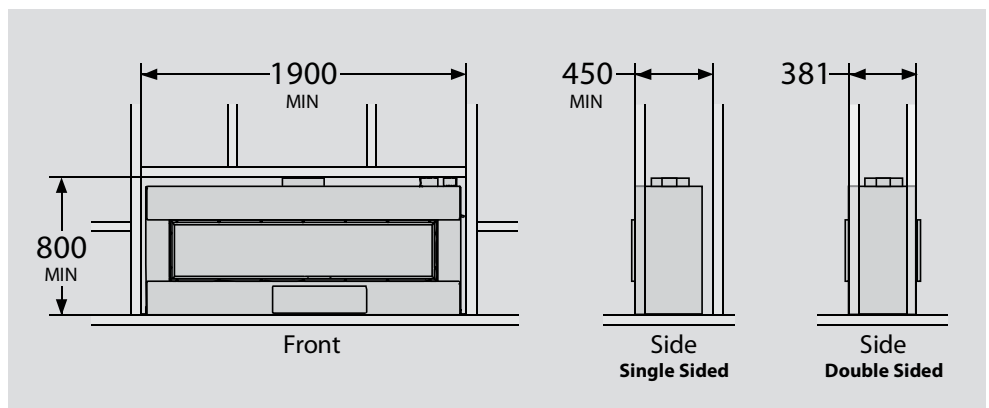

Mantle Clearances (mm)

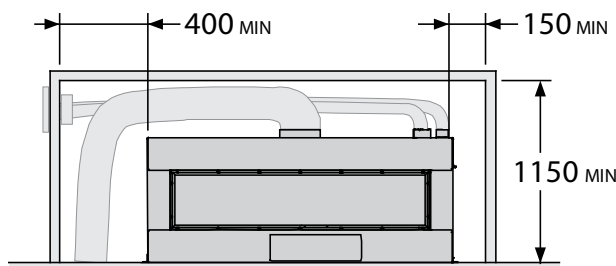

'Hutch' style cavity minimum dimensions (mm)

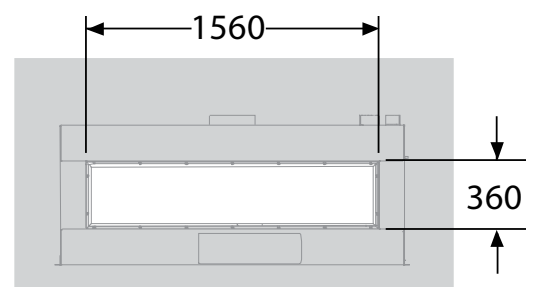

Wall opening size for frameless / no fascia (mm)

Ducting information:

This gas fire features a small network of ducting situated either in the ceiling or under the floor to distribute the heat generated by this fireplace. The maximum configurations for this ducting network are shown below and the diameters in mm.

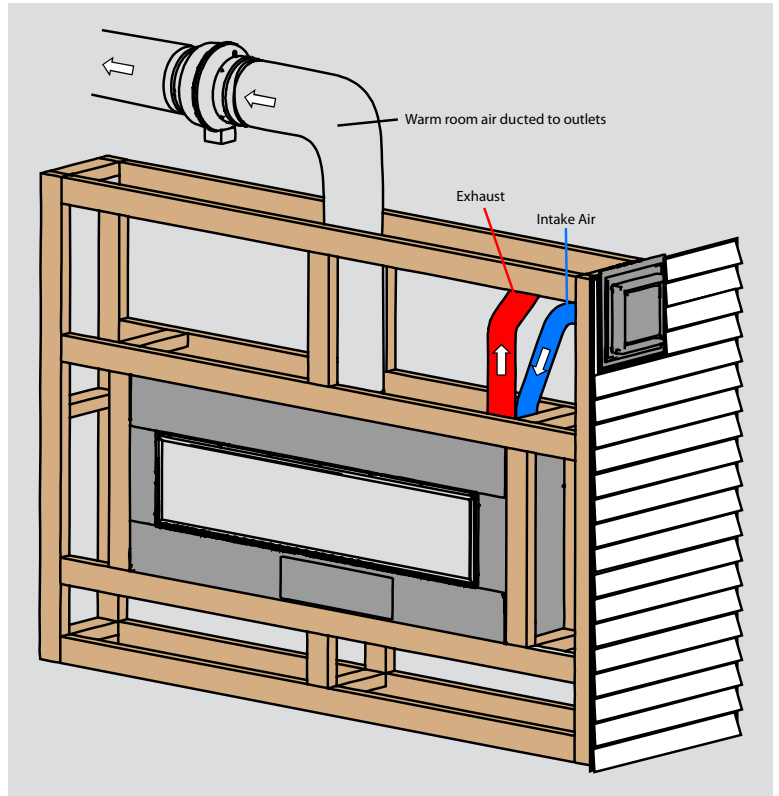
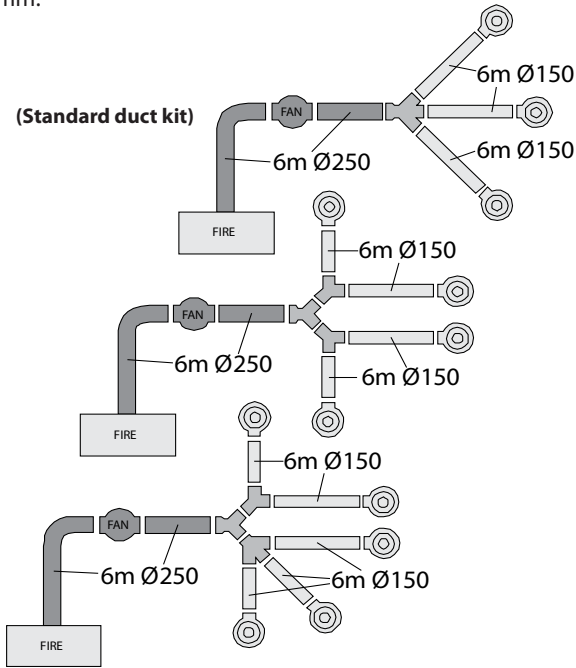

Flue information:

There are two basic types of flue configuration, using a vertical powerflue cowl, or a horizontal powerflue cowl. The horizontal offset of the terminal can be any amount up to the total flue length shown. You cannot flue down, ie allow the terminal to be lower than the outlet on the appliance.

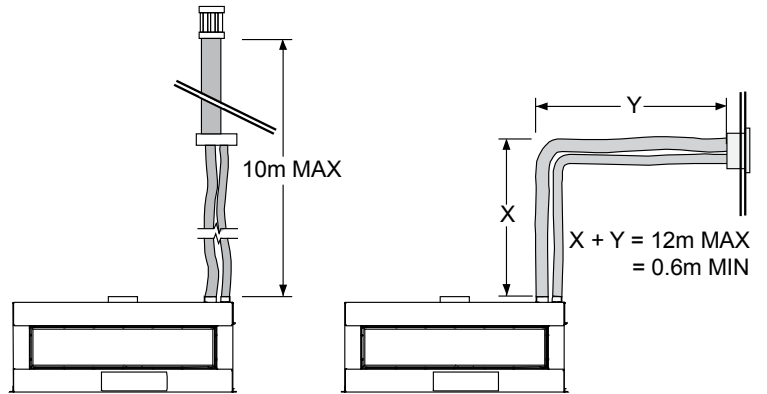

Cavity Size for Horizontal Powerflue:

When cutting the hole in the outside wall, be mindful of how the installation Horizontal Powerflue Wall Terminal will be finished, the installation must be weatherproof.

Ideal hole/cavity size for Horizontal Powerflue

X	298mm
Y	298mm
Z	175mm

* Note, Z dimension does not include allowance for flue which exists here as shown in the above diagrams. If the flue is exiting the powerflue and immediately going downwards, Z dimension will need to be at least 400mm to allow for the flue and flue bend radius.

