

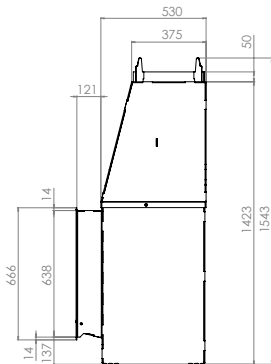

For further information or specifications, visit the technical section of our website [www.escea.com](http://www.escea.com) to view the latest product Installation Manual.

**Appliance Information**

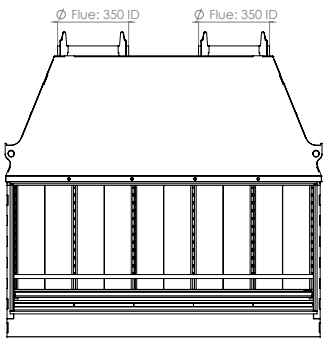
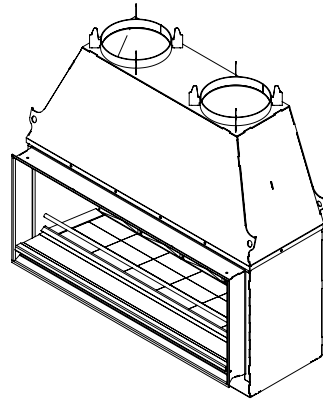
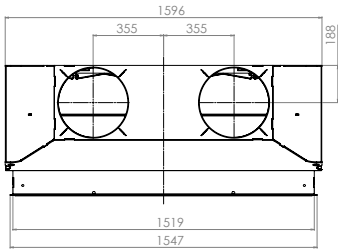

**Specifications**

Suitable for outdoors only  
Wood burning barbeque  
and outdoor fire

**Appliance Weight  
450kg**

The EK1550 requires 2 flues  
for correct operation

**Platform Construction**

The fire must be securely fastened to the platform using the fixing points on the base of the appliance. Please see the Installation Manual for more details.

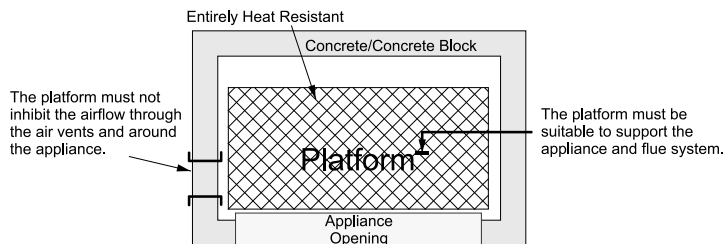

**Cavity Construction**

**Minimum Cavity Dimensions (mm):**

When the appliance forms part of a building, or is installed attached to the building, then the entire appliance must be fully enclosed in concrete material (concrete block and/or poured concrete) of 140mm thickness or greater.

Cladding over the concrete cavity can consist of any heat resistant material.

When the appliance is installed in a remote, freestanding structure that is not attached to or encompassed within the envelope of the building and is at least 2000mm from any combustible material in any direction, then the enclosure may be constructed from any heat resistant material. If any combustible material is within 2000mm of the fire in any direction, then the enclosure **must** comply with the concrete structure specified above.

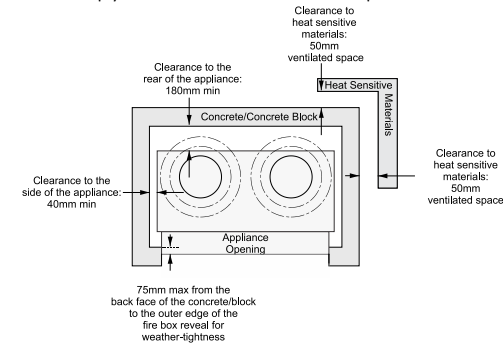

**Venting Requirements**

The air vent(s) can be any size or shape, provided that the total combined open surface area is at least 28000mm<sup>2</sup>.

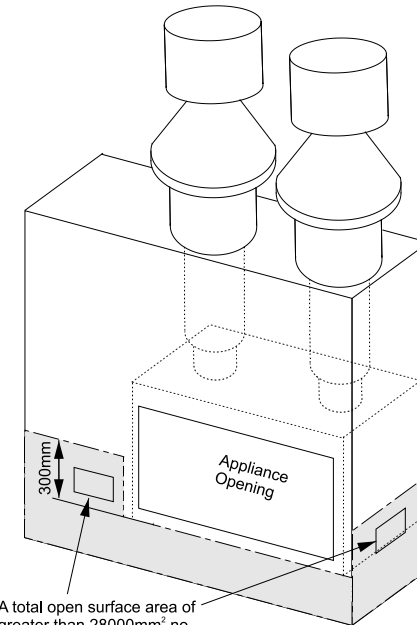

## Flue Information

### Flue Configuration

The flue must be installed in accordance with AS/NZS 2918 and the manufacturer's specifications.

The flue system requires the use of 2 x 350mm flues, 2 x 450mm flue liners, 2 x 550mm flue liners above the flashing, two 350mm to 650mm cones, and two flue terminals. It is recommended to use a minimum of 2.4m of flue.

The EK1550 requires **two** flues for proper venting of the cavity.

### Flashing Detail

Note: The flashing must consist entirely of heat resistant materials.

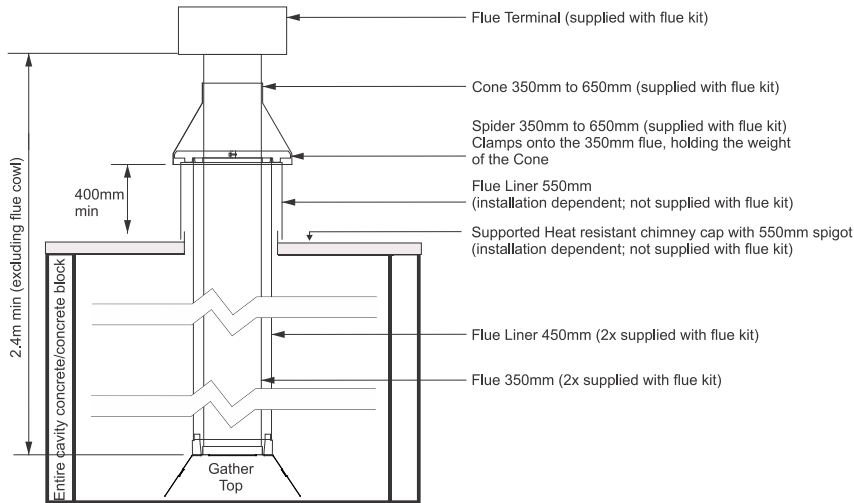

### Flueing Through a Roof

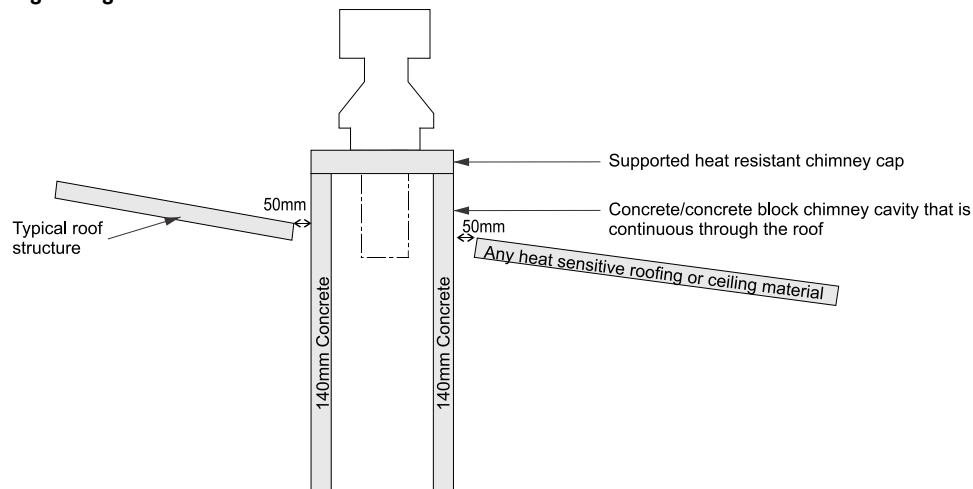

## Clearances

### Chassis and Flue Clearance

This appliance is designed for outdoor use **ONLY**.

A 50mm clearance must be maintained from the concrete enclosure to combustible materials. Any combustibles in front of the fire need to be no less than 2000mm from the opening of the fire and 1000mm to each side. It is recommended to install the fire with the opening 790mm above the floor.

Do not install a TV above this fire under any circumstances.

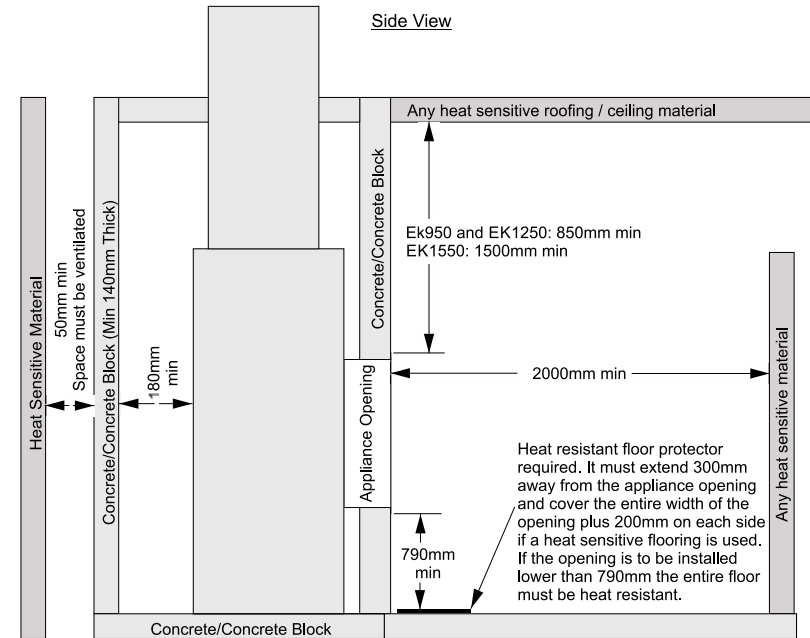

### Top View

