



**PACIFIC
ENERGY**

CANADA'S FINEST STOVES



GAS HEATERS



MADE IN CANADA, FOR CANADIAN WINTERS

MIRAGE

FREESTANDING GAS STOVE

Heating Capacity

56 m²

NG / LPG

Efficiency

66%



DESIGN

Simple touch operation and temperature management

Each Pacific Energy Gas Fireplace comes with an advanced comfort remote control. Using a Smart thermostat, your fireplace can automatically modulate flame height to optimise temperature management and room ambiance.



The Mirage represents the leading edge of freestanding design for small to medium spaces. The Mirage is beautifully clad with lustrous porcelain enamel offered in four solid colours: red, ivory, black and titanium. Inside each Mirage is a powerful engine; large formed finned heat exchangers result in high performance

heating efficiency while a highly reflective baffle and insulated interior firebox panels maximise temperature convection. A standard one-touch remote control simplifies operation; heat output and flame height are variable allowing complete control over heating, comfort, and appearance.

Panel Options



Black Porcelain



Red Porcelain

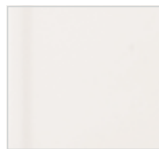

Ivory Porcelain

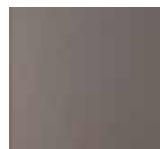

Titanium Porcelain

Media Options



Logset



Glass Burner

Absolute comfort with floor-level heat output

We all know hot air rises; so it makes sense to force hot air from the bottom rather than the top like conventional systems do. Thanks to the Mirage's unique floor level heat output system, you can maintain an ideal temperature from floor to ceiling. Sized for small to medium homes, define heating your living space with easy-to-use, high efficiency, contemporary elegance.

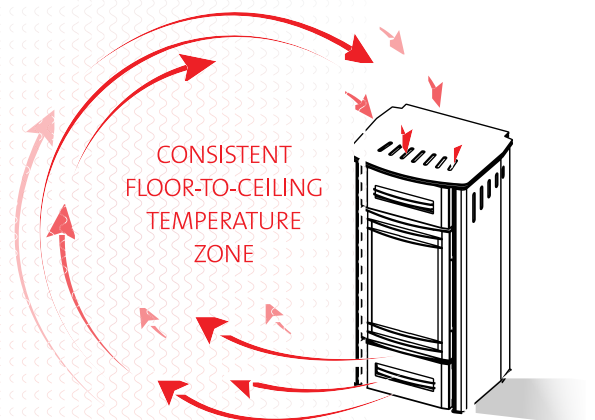

Heating Capacity

93 m² NG
80 m² LPG

Efficiency

67.5%

ESPRIT

LINEAR GAS FIREPLACE



The Esprit linear gas fireplace offers Pacific Energy's highest level of quality, technical innovation, and engineering in a modern landscape design. For maximum heat and ultimate energy efficiency, the Esprit utilises large finned heat exchangers and standard one-touch remote controls to provide quick, easy control over heat and added energy savings. Even at the lowest settings, flames are appealingly rich and full to gently warm the room.

Create a fireplace that uniquely complements your home with Pacific Energy's exclusive Design-A-Fire system. Whether you

choose a dramatic landscape of fire over tumbled glass, or the gentle ambiance of a driftwood logset, your new gas fireplace offers an expansive view of flame set against a backdrop of reflective lustrous porcelain enamel liners, designed to enhance the stunning flames.

For nights you just want mood, the Esprit can run in flame only mode, or crank up the 6 speed fan to warm up on those colder nights. The internal lights bring your heater to life without adding extra heat.

Surround Options



Louvered



Straight Edge



Contemporary Surround
Stainless Steel Front



Contemporary Surround
Matte Black Front

Media Options



Driftwood Logset



Glass Burner



Want more?
Add Stones to
your Glass Media

	ESPRIT	MIRAGE
Remote Control	Standard	Standard
Flame Settings	6	6
Flame only mode	Yes	Yes
Fan Settings	6	6
Manual Override	Yes	Yes
Thermostat	Yes	Yes
Firebox lights	Yes	No
Fuel Bed Options	Log / Glass / Stone	Logset / Glass
Flue Style	Direct Vent	Direct Vent
Top Flue	Yes	Yes*
Rear Flue	Yes*	Yes
Gas Type	NG / LPG	NG / LPG
Input	31.7MJ	19MJ
Output / Capacity	5.9kW / 93m ²	3.5kW / 56m ²
Warranty	2 Year Comprehensive / 10 Year Limited	

* Rear flue capability with additional elbow.

SAFETY

When designing any heat source, safety is always at the forefront. At Pacific Energy, we believe that with today's advanced technologies and materials, there's no need to compromise aesthetics for safety. That is why we've developed an integrated micromesh screen that creates a virtually invisible safety barrier, allowing a clear, unobstructed view of the flame as a standard feature for each model.

EFFICIENCY

Behind the legendary performance of Pacific Energy lies craftsmanship, experience, and next-generation technology. Large finned heat exchangers maximise heat convection while highly reflective baffles radiate heat. Heat output and flames are variable, allowing complete control of heating, comfort, and appearance.

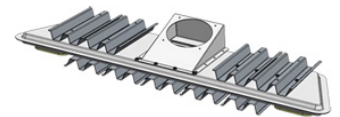

MIRAGE

Clearance to Combustibles

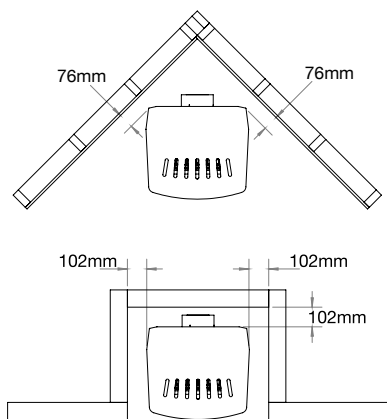

Unit Dimensions

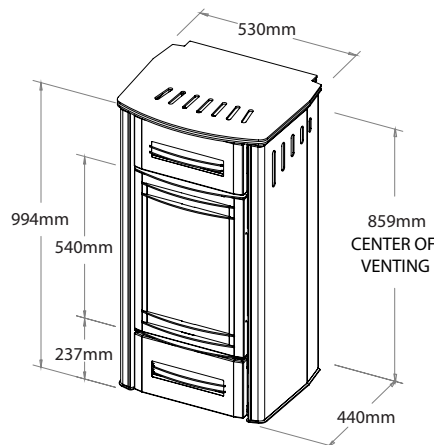

Flue Options

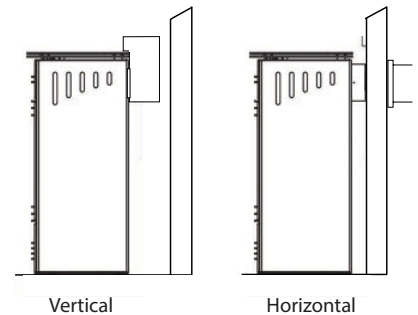

Vertical

Horizontal

*No hearth required. The Mirage can be installed onto timber flooring

ESPRIT

Framing Dimensions

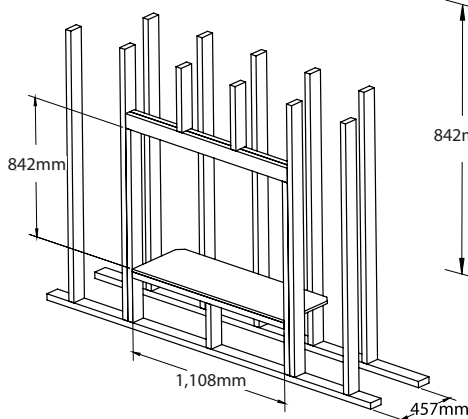

Unit Dimensions

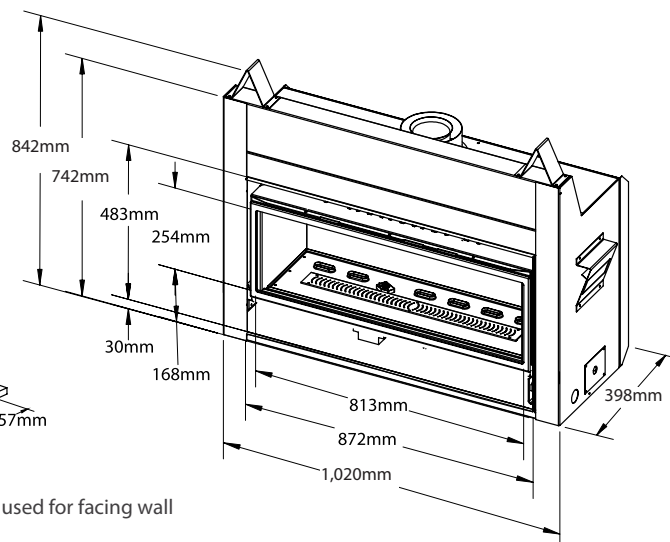

Flue Options

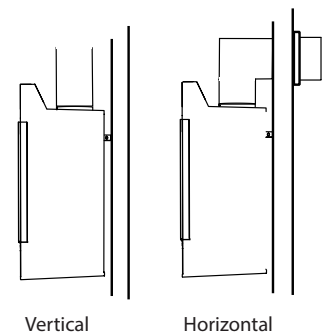

Vertical

Horizontal

*12mm non-combustible material must be used for facing wall

Proudly distributed by Pivot Stove & Heating Australia
For more information and current product updates,
pivotstove.com.au



Pacific Energy Fireplace Products Ltd proudly supports the activities of Landcare Australia through its membership of the AHHA

#Information for reference only. Installations should be based on manuals and rating labels. Specifications subject to change.